

## PERFORMANCE DATA SHEET NEMA PREMIUM NR CAN NEMA 12 - 12

Catalogue #: MPOP-77

HP	kW	Voltage	S.F. @ 60Hz	EFF.	P.F.	Frame	Design	L.R. Amps
100	74,60	575	1,15	95,4%	0,87	404T	B	580

60 Hz								Code	F.L. RPM
FLA									
208	230	416	460	480	575	600			
/	/	/	/	/	89,6	85,87	G	1785	

50 Hz								Code	F.L. RPM
FLA			S.F. @ 50Hz	Efficiency	Power Factor				
190	380	415							
/	/	/	/	/	/	/	/	/	

Wgt. Lbs	PH	Duty	Insul. Class	Amb.	Elevation	Temp. Rise° C
1058	3	Cont.	F	40°C	1000M (3300 Ft)	61

% Efficiency		% Power Factor		Torque		Winding Resist. Ω	Safe Cold Start (Secs)
Full Load:	95,4%	Full Load:	0,87	Full Load Ft/Lbs	294,2		
3/4 Load:	95,0%	3/4 Load:	0,84	Locked Rotor %	150		
1/2 Load:	94,6%	1/2 Load:	0,77	Break Down %	240	0,08	20

Rotor Inertia Wk2 Lb-Ft2	Max Load Inertia Wk2 Lb-Ft2	Shaft Material	Frame Material	DE Bracket Type	ODE Bracket Type	Enclosure	NEMA Rating	Lead Wire Size
21,83	600	Standard	Cast Iron	Standard	Standard	ODP	IP23	6AWG

Ball Bearings		Grease	Mount Type	Orientation	Paint	Sound Pressure @ 3FT	Sound Power
DE	ODE						
NU318	6314	Mobil PolyrexEm	Rigid	Horizontal	Green	86	98

Inverter Duty. Motor meets MG1 parts 31.4.4.2	Constant Torque Range	Variable Torque Range	Constant HP RPM
		10:1	20:1

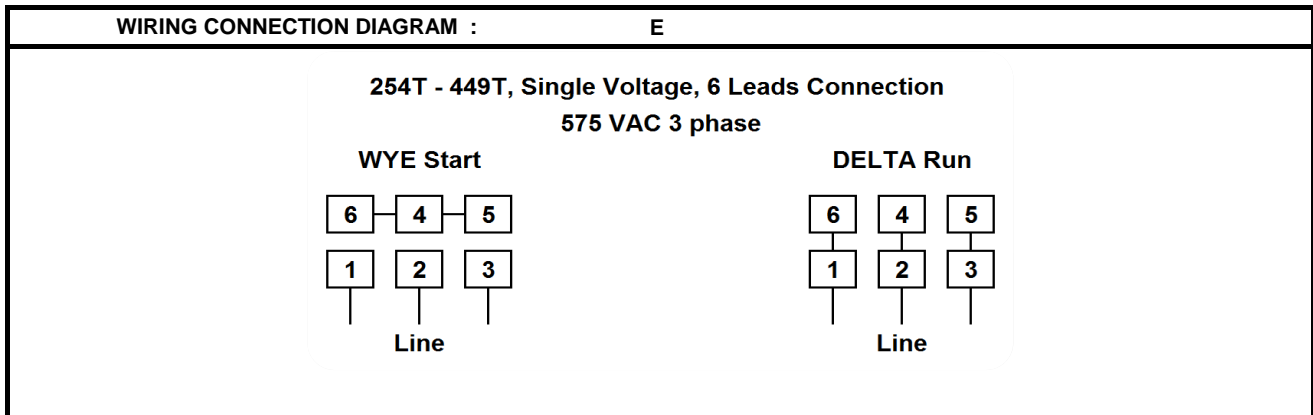

Date: 2020-02-25  
 Customer: \_\_\_\_\_  
 Contact: \_\_\_\_\_  
 Submittee: J.C. Lavallée

Catalogue #: **MPOP-77**

NEMA PREMIUM NR CAN NEMA 12 - 12										
HP	VAC	RPM	Enclosure	Frame	Frequency	Design	Poles	LR Code Letter	Insulation Class	Temp. Rise °C
100	575	1785	ODP	404T	60	B	4	G	F	61
	0Hz	6Hz	15Hz	30Hz	45Hz	60Hz	75Hz	90Hz	105Hz	120Hz
Amps	89,6	89,6	89,6	89,6	89,6	89,6	89,6	89,6	89,6	89,6
RPM	0	178,5	446,25	892,5	1338,75	1785	2231,25	2677,5	3123,75	3570
Torq ft.lb	235,38	294,23	294,23	294,23	294,23	294,23	235,38	196,15	168,13	147,11
Peak Tq ft.lb	323,65	647,31	647,31	647,31	647,31	647,31	517,84	431,54	369,89	323,65
HP	0	10,0	25,0	50,0	75,0	100,0	100,0	100,0	100,0	100,0
	Locked Rotor	Pull-Up	Breakdown	Rated Load	Idle	Duty	S. F.	Ambient	Elevation	dBA @ 1M
Speed (RPM)	0,0	756	1440	1785	1800	Continuous	1,15	40°C	3300 ft	86
Current (Amps)	580,0	493,0	345,1	89,6	28,0	VFD Rating: Meets MG1 parts 31.4.4.2				
Torque (ft-lbs)	441,3	331,0	706,2	294,2	0,0	C.T.	10:1	V.T.	20:1	

Motor Speed Data

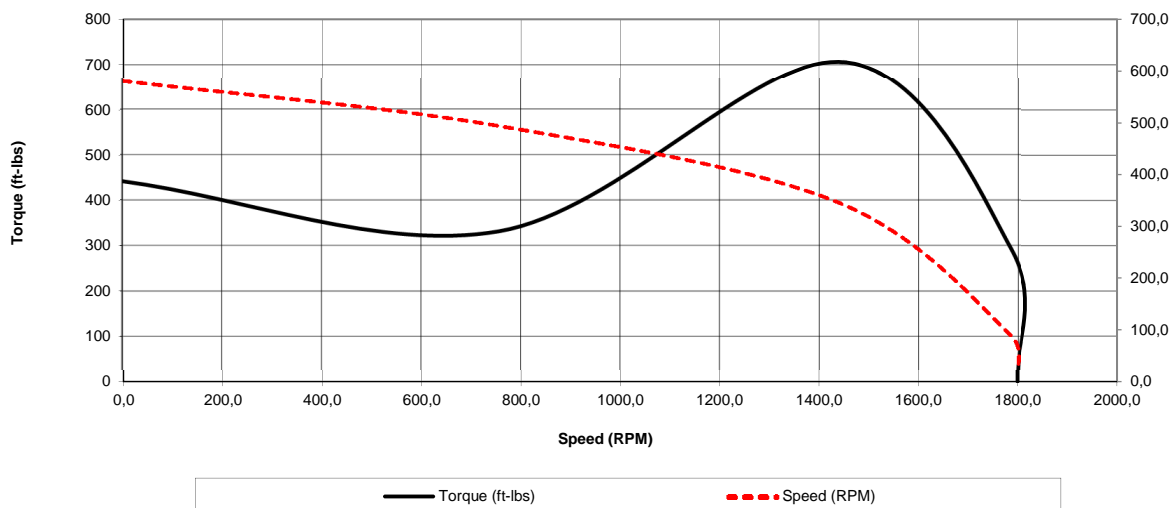

Motor Torque Capability vs RPM

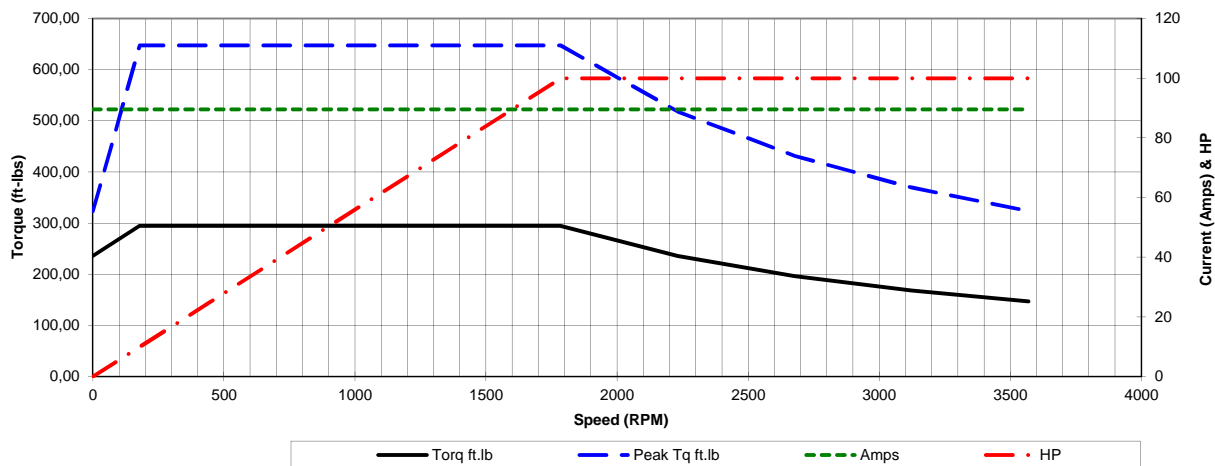



Date: 2020-02-25  
 Customer: \_\_\_\_\_  
 Contact: \_\_\_\_\_  
 Submittee: J.C. Lavallée

Catalogue #: **MPOP-77**

NEMA PREMIUM NR CAN NEMA 12 - 12										
HP	VAC	RPM	Enclosure	Frame	Frequency	Design	Poles	LR Code Letter	Insulation Class	Temp. Rise °C
100	575	1785	ODP	404T	60	B	4	G	F	61
Load %	0%	25%	50%	75%	100%	125%	150%			
Amps	28,00	34,70	50,50	69,20	89,60	113,59	137,91			
Torq ft/lbs	0	73,10	146,34	219,88	293,64	367,84	442,34			
RPM	0	1796,25	1792,5	1788,75	1785	1781,25	1777,5			
Eff	0	93,21	94,60	95,00	95,40	95,40	95,40			
PF	0	57,9	77	84	87	86,4	85,4			
	Locked Rotor	Pull-Up	Breakdown	Rated Load	Idle	Duty	S. F.	Ambient	Elevation	dBA @ 1M
Speed (RPM)	0	756	1440	1785	1800	Continuous	1,15	40°C	3300 ft	86
Current (Amps)	580	493,0	345,1	89,6	28	VFD Rating: Meets MG1 parts 31.4.4.2				
Torque (ft-lbs)	441,34	331,01	706,15	294,23	0,0	C.T.	10:1	V.T.	20:1	

